

Inflation and real activity with firm-level productivity shocks: a quantitative framework*

Michael Dotsey, Robert G. King and Alexander L. Wolman[†]

December 2005; under revision October 2006

Abstract

Recent measurements of the extent of price stickiness indicate that there is a substantial amount of relative price variability. Extending our prior state-dependent pricing model, we study a setting in which there are discrete "micro states" interpreted as stochastic productivity variations at the firm level. The new model shares the "generalized partial adjustment" implications of our prior analysis and also its tractability for macroeconomic analysis. Notably, it can be used to study the strength of general equilibrium influences on price adjustment and the consequences of alternative monetary policy rules.

Without aggregate uncertainty, the microstate model has rich implications for the dynamics of prices, including links from firm level productivity to the likelihood of price adjustment ("conditional hazards") and magnitudes of price adjustments. In this steady state – where firms face substantial uncertainties while aggregates are constant – there are also implications for the cross-sectional distribution of relative prices and price changes, among other things.

When linearized around this stationary point, the microstate model also has important implications for the dynamic of aggregate economic activity. To exposit these, we build quantitative examples which we link to recent studies in the literature.

*Andrew Foerster and Michael Johnston provided outstanding research assistance. This paper does not represent the views of the Federal Reserve System or the Federal Reserve Banks of Philadelphia or Richmond.

[†]Federal Reserve Bank of Philadelphia; Boston University, Federal Reserve Bank of Richmond and NBER; Federal Reserve Bank of Richmond.

1 Introduction

Macroeconomics frequently abstracts from microeconomic uncertainties so as to be able to focus on the nature and consequences of aggregate shocks. Real business cycle analysis has mainly concerned the macroeconomic effects of productivity shocks that are common across production units, abstracting from the considerable differences in productivity across plants at a given time and for the considerable uncertainties about a given plant's productivity over time. New Keynesian macroeconomics has investigated the macroeconomic effects of nominal and real aggregate shocks, largely abstracting from fluctuations in relative productivity and demand, so as to explore the consequences of asynchronous price-setting by firms.

By contrast, in this paper, we provide a framework within which routine quantitative macroeconomic analysis can be conducted in the presence of stochastic heterogeneity in prices and productivity at the microeconomic level. For example, our framework is capable of studying the following five topics that we consider to be critical for the ongoing analysis of state-dependent pricing.

1. the relationship of price-adjustment hazards at the level of individual firms to the extent of micro-level productivity fluctuations and the extent of price adjustment costs;
2. the implications of micro productivity fluctuations and the extent of price adjustment costs for the cross-sectional distribution of relative prices and the distribution of nominal price changes;
3. the consequences of adding microeconomic productivity uncertainty to existing models of the dynamic interaction of inflation and output;
4. the evaluation of the strength of general equilibrium effects on firm and aggregate patterns of price adjustment;
5. the consequences of alternative monetary policy rules for the frequency of price adjustment as well as the dynamics of inflation and output.

More particularly, the current “microstate” framework extends our prior state-dependent pricing model – Dotsey, King and Wolman [1999] – to incorporate fluctuating microeconomic productivity with an eye to studying issues raised by two sets of recent research. First, recent empirical studies of microeconomic price dynamics by Bils and Klenow [2004] and Klenow and Kryvtsov [2004] for the U.S. suggest that there is a great deal of relative price

volatility and price flexibility, as measured by the average magnitude of price changes and by the frequency of price changes. These findings are largely echoed in the findings of the Eurosystem’s Inflation Persistence Network, but with some interesting differences that are also worthy of further study. Second, recent theoretical studies by Klenow and Kryvtsov [2004], Golosov and Lucas [2003] and Midrigan [2006] are skeptical about aspects of previous SDP models. Notably, Golosov and Lucas [2003] argue that (i) idiosyncratic cost-type shocks are necessary for matching the micro data on price adjustment, and (ii) when such shocks are incorporated in a state-dependent pricing model, there is very little nonneutrality. In essence, Golosov and Lucas argue that the exact neutrality result of Caplin and Spulber [1987] is a reasonable guide to the aggregate implications of state-dependent pricing. On the other hand, Klenow and Kryvtsov [2004] study the consistency between DKW model – in which there are no idiosyncratic productivity shocks – and data on the frequency of price adjustment. They argue that a realistic calibration requires that there be such strong assumptions on adjustment costs that the DKW model delivers essentially the same macro implications as a time dependent pricing (TDP) model built along Calvo [1983] lines. Finally, like Golosov and Lucas, Midrigan [2006] constructs a state-dependent pricing model with idiosyncratic shocks, but Midrigan argues that the model is consistent with significant non-neutralities, in contrast to Golosov and Lucas. Key to this result are the assumptions that the idiosyncratic shocks have a fat-tailed distribution, and that multi-product firms face economies of scale in price adjustment.

Our prior research suggests the existence of an important middle ground in which there are both substantial non-neutralities and in which SDP models have very different implications from TDP models. On one level, the original DKW model was constructed precisely to allow for analysis of state-dependent pricing in environments that were richer and more realistic than those of the early works of Caplin and Spulber [1987] and Caplin and Leahy [1991], where monetary shocks were neutral either toward output or the price level. Working in a quantitative general equilibrium model, we showed that incorporating SDP into a standard modern model led to transitory dynamics in both the price level and output in response to a monetary shock. We argued that the details of these responses would depend in important ways on the structure of the model: on the average rate of inflation, on the monetary policy rule, on the behavior of marginal cost, on the elasticity of demand and so on.

In more recent work, Dotsey and King [2005] study how several basic economic environments are affected by the replacement of time-dependent pricing with state-dependent pricing. In particular, among other exercises, they contrasted the pricing implications of models including the conventional constant elasticity demand specification of Dixit and

Stiglitz [1976] with an alternative proposed by Kimball [1995], in which firms face a variable elasticity in line with a smoothed-off kinked demand curve. Since components of that study will serve as background to the present one, we review some of its key components in section 2 below. Then, in section 3, we outline the key components of our stochastic adjustment framework with microstates. In section 4, we consider the stochastic steady-state of our new framework, displaying how it can be used to make predictions about the panel data like that studied by Bills and Klenow or the member teams from the Inflation Persistence project. We display these implications for both the DS demand structure and for the K demand structure. In section 5, we turn to macroeconomic dynamics. Using precisely the same specifications as in Dotsey and King [2005], but with some large micro productivity shocks added, we find that there are indeed important implications of adding microstates, but that these differ sharply across demand structures. In particular, we find that adding microstates to a model with DS demand has *major* effects on impulse responses to monetary disturbances and that the responses in the micro state model are ones that would appear *more* realistic to a typical macroeconomist. At the same time, we find that the addition of microstates has *minor* effects on the impulse responses with K demand. Our plan going forward is to study the model’s dynamics when it is calibrated to match microeconomic evidence on price adjustment.

2 Background

Our starting point is the analysis of Dotsey and King [2005], henceforth DK, which explores a battery of macroeconomic models under the alternative assumptions of time-dependent and state-dependent pricing. In this brief section, we review some of the findings of that investigation, so as to provide the background for the analysis of micro-state models. The review of findings is centered around Figures 1 through 5, which are identical to the first five figures in DK.

2.1 Alternative demand structures

Most modern models in macroeconomics, trade and economic growth study monopolistic competition equilibria under the assumption that firms face constant elasticity demands for differentiated products. However, this is arguably an assumption of convenience in analytical modeling and it can easily be dropped in quantitative modeling. Further, Kimball [2005] and others have argued that alternatives to the constant elasticity specification have important implications for pricing.

Figure 1 shows the two alternative demand structures studied in DK2005, a constant elasticity specification of the DS (Dixit-Stiglitz) form and an alternative with a specific K (Kimball) form. Each is structured so that there is an elasticity of 10 at a relative quantity of unity, which is a conventional value used in macro modeling. But the K specification has the property that the elasticity of demand falls with the relative quantity, as in the textbook “kinked demand” analysis. This figure displays demand, marginal revenue, elasticity and profit implications at various relative quantity levels. In addition, it shows the relative quantity levels that obtain in an inflationary steady-state given the optimal pricing patterns of firms (these are marked with an ‘o’ for the DS specification and with an ‘*’ for the K specification).

2.2 Steady state adjustment rates and sticky price fractions

Within an SDP setting, these alternative demand structures have implications for the frequency of price adjustment and the fraction of firms that choose to keep their nominal prices fixed. Figure 2 illustrates these implications in an inflationary steady state. The first panel shows the hazard rate for firms by the age of their nominal price: the rising hazard is a characteristic of SDP models. However, the hazard rate rises much more sharply with K demand than with DS demand. The second panel shows the implications of this adjustment pattern for the fraction of firms that actually charge a j -period old price: there are fewer firms with old prices under K demand than under DS demand.

2.3 Profits and relative prices

To pursue the reasons for the outcomes in Figure 2 and to provide a background for dynamic pricing, Figure 3 shows how profits depend on the relative price charged by a firm. For the K demand firm, the “profit hill” is much more steep than for the DS demand firm. This feature leads the firm facing a K demand to choose a more tightly clustered pattern of optimal prices than its DS counterpart. More specifically, the K demand firm chooses a lower initial relative price (the rightmost ‘*’ in the figure) than its DS counterpart (the rightmost ‘o’ in the figure). Further, it is more willing to pay an adjustment cost because its profits fall off more sharply when inflation erodes the real value of its relative price, as it must with firms setting nominal prices in an inflationary steady-state.

2.4 Macroeconomic dynamics

A standard experiment in sticky-price macroeconomic models is to consider the effect of a monetary shock. In DK2005 and in the present paper, we consider a monetary shock that has a 1% effect on impact and then gradually builds up to an ultimate 2% level (this is a result of positive autocorrelation in money growth of .5, which is a rough estimate for the U.S.). The DKW framework permits solution of a general equilibrium macroeconomic model with SDP using linear systems methods, so that impulse response analysis to this and other shocks can easily be conducted.

Figure 4 shows the response to a monetary shock in a DS demand model under SDP. A representative macroeconomist's reaction to this figure would be that these outcomes are very far from estimates of the effects of monetary shocks and from the implications of other sticky price macroeconomic models. There are aggressive responses by those firms which choose to adjust prices (the ' \diamond ' path) which initially overshoot and then oscillate around the ultimately higher level of 2%. There are also oscillatory responses in output, real marginal cost, the price level and inflation. While these oscillatory responses are far from estimates, they do illustrate that SDP dynamics can be very different from TDP dynamics. In a model that constrained firms to always adopt the steady-state adjustment patterns shown in Figure 2, for example, there would be a prolonged initial real expansion as the price level gradually moved up toward the long-run level. That is, the unorthodox dynamics are a result of the incentives that firms have to change the timing of their adjustments.

Figure 5 shows the response to a monetary shock in a K demand model under SDP. With this demand structure, firms do not want their nominal prices to get much out of line with the general price level so as to avoid the profit losses illustrated in Figure 3. A state-dependent pricing model allows them to do so. In particular, they can set a nominal price not-too-different from the price level now (the ' \diamond ' path) knowing that they can choose to adjust later. Further, when there is a shift in the price level, as in Figure 5, this alters the desirability of price adjustment for firms, in ways that are more fully explored in DK2005. The K demand model produces novel sticky price dynamics, with inflation peaking after output, precisely because firms can choose the timing of their adjustments. Working in a time-dependent setting, Mankiw [2001] argued that no sticky-price model could generate such a pattern of outcomes, which he described as consistent with business cycle experience in the U.S. and other countries.

2.5 Summing up the background information

This section has illustrated that SDP models designed along DKW lines have implications, along the lines of Figure 2, for panel data sets of the type studied in much recent work. The SDP assumption also means that general equilibrium dynamics influence the choice of adjustment timing by firms and, in turn, that the choice of adjustment timing by firms affects the nature of general equilibrium dynamics.

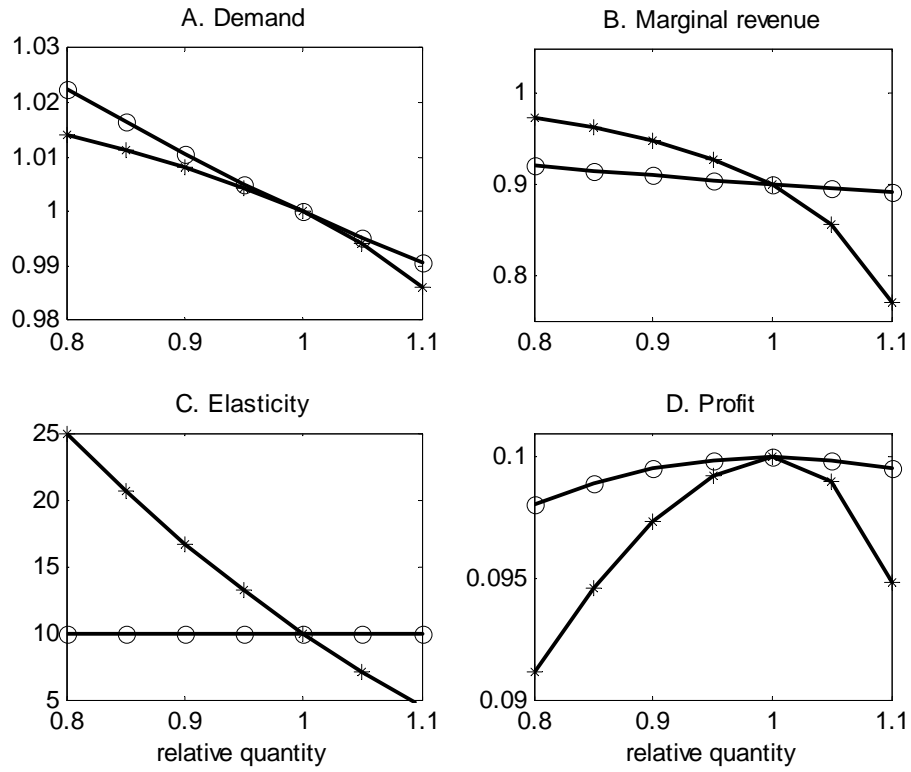

Figure 1: Alternative Demands: Dixit-Stiglitz (o) and Kimball Kink (*)

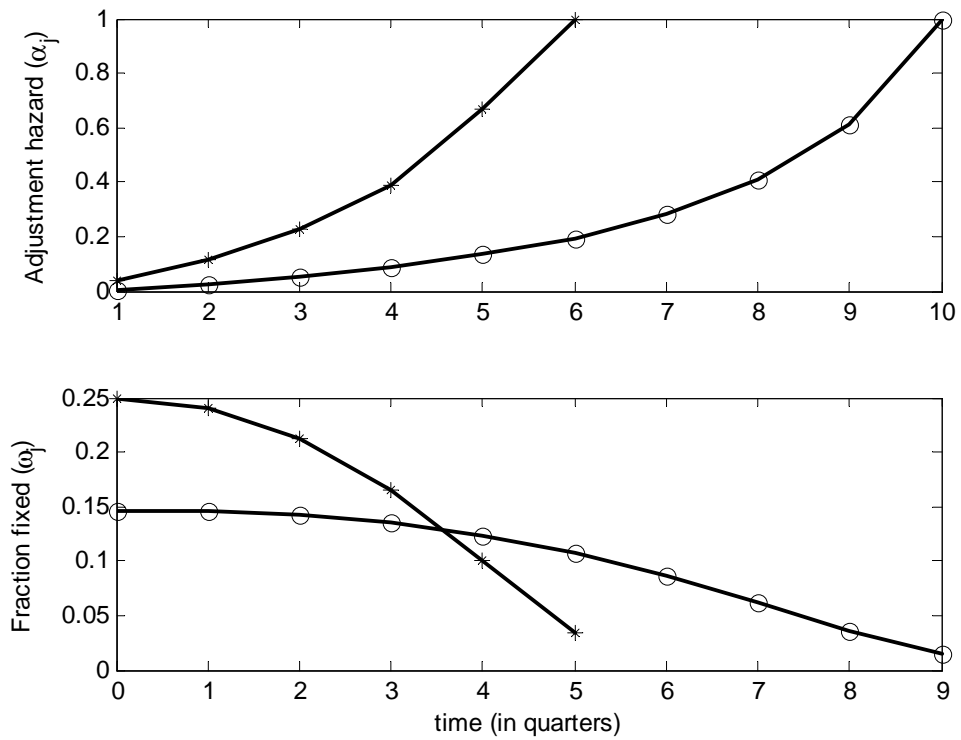

Figure 2: Adjustment rates (α) and vintage fractions (ω) for global labor market models with DS demand (o) and K demand (*)

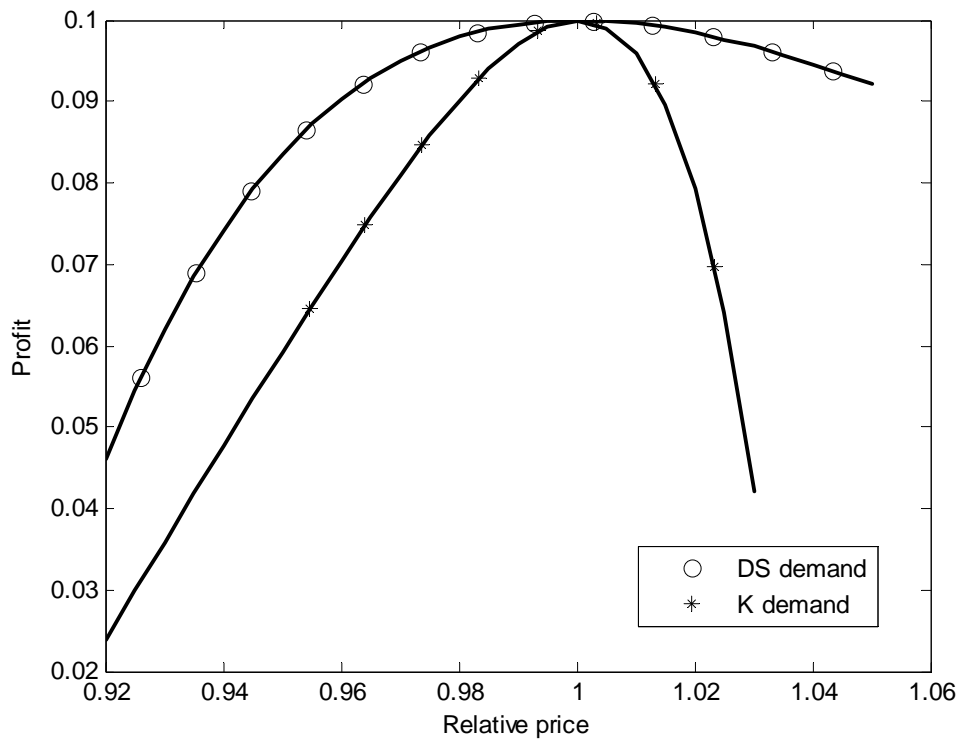

Figure 3: Profit for DS and K demand at $\psi = \frac{\varepsilon-1}{\varepsilon} = .9$

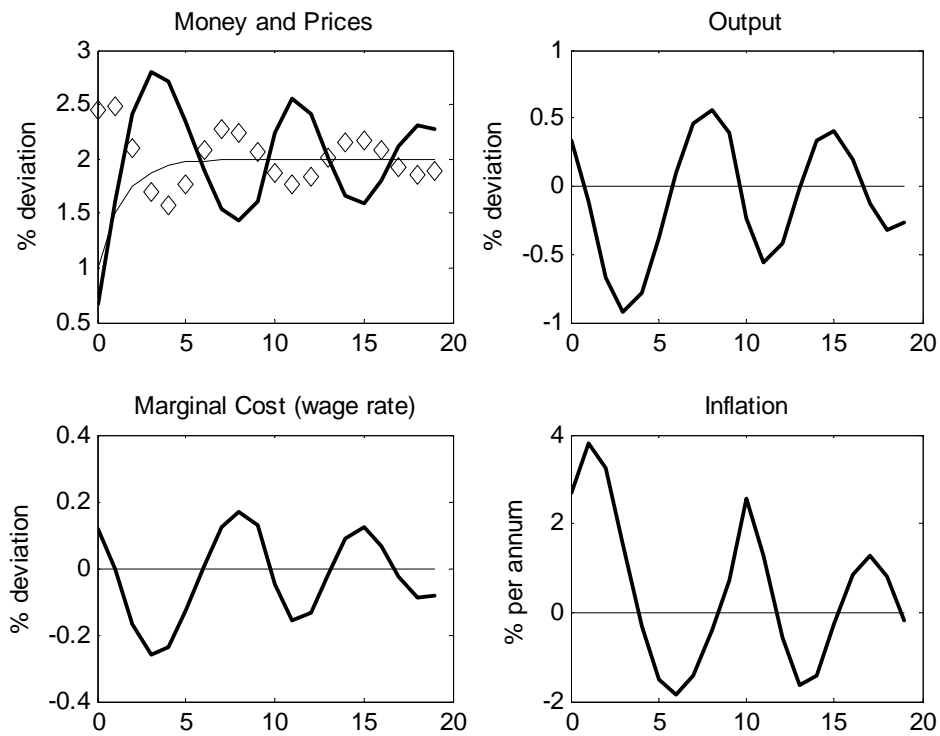

Figure 4: Dynamic Responses to a Monetary Shock with DS demand. The three responses in the first panel are the money stock (light line); the price level (darkline); and the optimal price set by adjusting firms (\diamond).

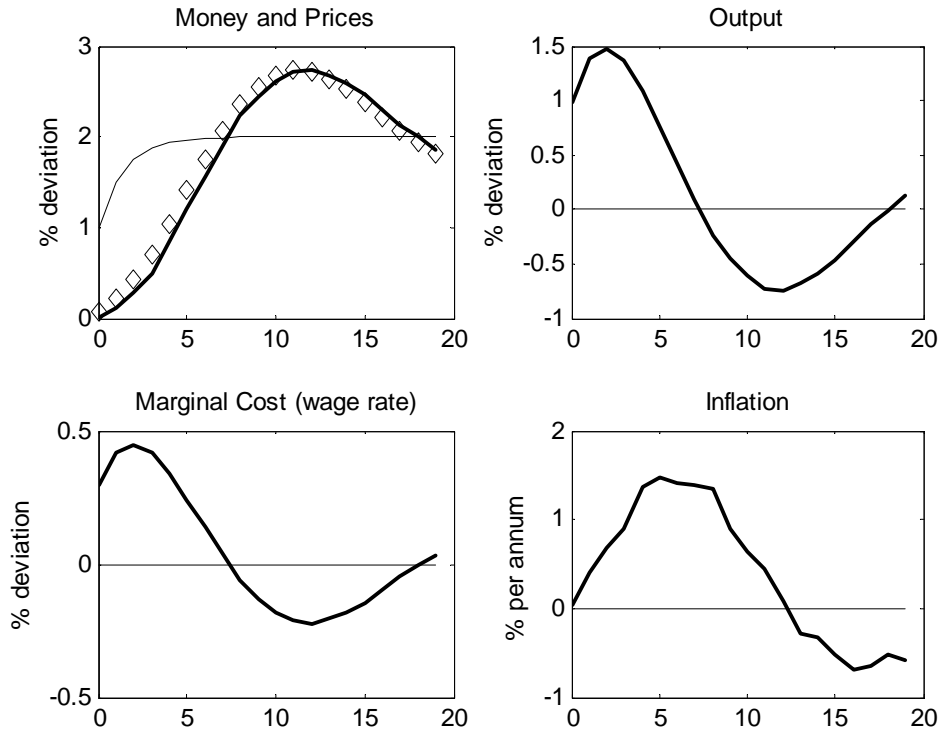

Figure 5: Dynamic Responses to a Monetary Shock with K demand. The three responses in the first panel are the money stock (light line); the price level (darkline); and the optimal price set by adjusting firms (\diamond).

3 A stochastic adjustment framework

To study the effect of serially correlated firm-level shocks, which we call microstates, we now extend the framework of DKW [1999] with an eye to retaining the tractable general equilibrium analysis that can be conducted in that setting. While we consider these microstates to be productivity shocks in the current analysis, analysis of demand shocks would be formally similar.

3.1 Discrete microstates governed by a Markov chain

The microstate of a firm is given by its productivity level, which we call e_t . We assume that there are K different levels of microproductivity that may occur, \underline{e}_k , $k = 1, 2, \dots, K$, so that a firm of type k at date t has total factor productivity

$$a_{kt} = a_t \underline{e}_k \tag{1}$$

where a_t a common productivity shock work. We assume that the micro productivity levels are ordered so that $\underline{e}_1 < \underline{e}_2 < \dots < \underline{e}_K$.

There may be stochastic transitions between microstates, governed by a state transition matrix, Q , where

$$q_{kf} = \text{prob}(e_{t+1} = \underline{e}_f | e_t = \underline{e}_k) \tag{2}$$

For ease below, we also use the notation $q(e'|e)$ to denote the conditional probability of state e' occurring next period if the current state is e .

We assume that these transitions are independent across firms and that there is a continuum of firms, so that the law of large numbers applies. The stationary distribution of firms across microstates is then given by a vector Φ such that

$$\Phi = Q^T * \Phi$$

That is, the k^{th} element of Φ gives the fraction of firms in the k^{th} microproductivity state (these firms have productivity level \underline{e}_k).¹

¹The stationary probability vector can be calculated as the eigenvector associated with the unit eigenvector of the transpose of Q . See, for example, Kemeny and Snell (1976).

3.2 An individual firm and its adjustment

Suppose that the aggregate state of the economy is given by a vector s . Consider a firm which had a relative price of ϱ last period and which has a current microstate of e . A generalized partial adjustment model – a generalized (S,s) model in the language of Caballero and Engel [1999]– requires that there is an adjustment probability

$$\alpha(p, e, s) \tag{3}$$

for this firm. In this expression, $p = \varrho/\pi(s)$ is the firm’s relative price if it does not adjust, which depends on the (gross) inflation rate $\pi(s)$ and, thus, on the state of the economy. In addition, the adjustment rate depends on the microstate e and the aggregate state s , since each can influence the costs and benefits of adjustment. Probabilistic adjustment by the firm is rationalized by introduction of additional idiosyncratic shocks which are discussed further below.

If the firm adjusts, then it chooses an action – a new price – that is a function of the macro and microstates,

$$p^*(e, s) \tag{4}$$

but not on ϱ or the idiosyncratic considerations which lead only a fraction of firms with p, e, s to adjust.

3.3 Optimal pricing and adjustment

Consider a firm which faces a demand $d(p, s)y(s)$ for its output if it is charging price p . Following DKW, we assume that this firm faces a fixed cost of adjustment ξ , which is drawn from a continuous distribution with support $[0, \mathcal{B}]$.

We find it convenient to describe the optimal adjustment of this firm as involving three value functions:

- its value if it does not adjust, which we call \underline{v} ;
- its value if it has a current adjustment cost realization of 0, which we call v^o .
- its maximized value given its actual adjustment cost ξ , which we call v .

That is, the market value of a firm is governed by

$$v(p, e, s, \xi) = \max \{ \underline{v}(p, e, s, \xi), [v^o(e, s) - \lambda(s)w(s)\xi] \} \tag{5}$$

if it has relative price p ; microstate e ; macrostate s ; and a stochastic adjustment cost draw of ξ . This market value is the maximum of two components, which are its value conditional on adjustment ($[v^o(e, s) - \lambda(s)w(s)\xi]$) or nonadjustment ($\underline{v}(p, e, s, \xi)$).

The nonadjustment value \underline{v} obeys the Bellman equation,

$$\underline{v}(p, e, s) = [\lambda(s)z(p, e, s) + \beta Ev(p', e', s', \xi') | (p, s)] \quad (6)$$

with $p' = p/\pi(s')$. That is, the value \underline{v} is based on continuing with the current relative price p for at least one additional period: it is based on the valuation of state contingent cash flows $\lambda(s)$; the flow of real profits $z(p, e, s)$; and the discounted expected future value $\beta Ev(p', e', s', \xi')$, given that $p' = p/\pi(s')$.

The “costly adjustment value” is given by the value of the firm if it is free to adjust, $v^o(e, s)$, less the cost of adjustment, which depends on the macro state through $\lambda(s)w(s)$ and also on realization of the random adjustment cost ξ . In turn, the “free adjustment value” v^o obeys

$$v^o(e, s) = \max_{p^*} \{ \lambda(s)z(p^*, e, s) + \beta Ev(p', e', s', \xi') \} \quad (7)$$

with $p' = p^*/\pi(s')$.

Notice that there are asymmetries in the determinants of these values. The nonadjustment value $\underline{v}(p, e, s)$ depends on the relative price, the microstate and the macro-state but not on the adjustment cost ξ because this is not paid if adjustment does not take place. The free adjustment value $v^o(e, s)$ does not depend on the relative price (since the firm is free to choose a new price) or the adjustment cost ξ (since the adjustment decision involves a fixed cost).

3.4 Optimal adjustment

As in other generalized partial adjustment models, such as the prior DKW analysis of price adjustment, the firm adjusts if

$$[v^o(e, s) - \lambda(s)w(s)\xi] > \underline{v}(p, e, s).$$

Accordingly, there is a threshold value of the adjustment cost, such that

$$\underline{\xi}(p, e, s) = \frac{v^o(e, s) - \underline{v}(p, e, s)}{\lambda(s)w(s)} \quad (8)$$

Firms adjust with lower cost and firms do not adjust with higher costs.

The fraction of firms that adjust, then, is

$$\alpha(p, e, s) = G(\underline{\xi}(p, e, s)) \tag{9}$$

where G is the cumulative distribution of adjustment costs. The adjustment decision depends on the state of the economy, but it also depends on the distribution of adjustment costs, both directly and through the incentives that firms have to wait for a low adjustment cost realization.

3.5 Dynamics and accounting

A key feature of our framework is that we will track a distribution of firms that depends on previously set prices and on evolving levels of micro productivity, since we want to study the effects of this joint distribution on macroeconomic activity. Although the discussion to this point stresses that the decision problem of a firms can be formulated without reference to the sort of vintage structure employed in DKW, it is useful to develop this structure for the purpose of tracking the distribution of relative prices, conceptually and in our computational work. In this context, we also introduce explicit dates.

The core mechanics are as follows. We start with a joint distribution of relative prices and productivity which prevailed last period. This distribution is then influenced by the effects of microproductivity transitions (Q), the adjustment decisions of firms ($\alpha(p, e, s)$); and the effects of inflation on relative prices. The net effect is to produce a new distribution of relative prices prevailing in the economy. Table 1 summarizes some of the key notation and equations.

Table 1: Conceptual and accounting elements in microstate model

Concept	Symbol	Comment
past relative price	$p_{j-1,h,t-1}$	$h =$ historical state when price set (at $t - j$)
past fraction	$\omega_{j-1,l,h,t-1}$	$l =$ microstate at t-1
current fraction	$\theta_{j,k,h,t}$	$\theta_{jkh t} = \sum_l q_{lk} \omega_{j-1,l,h,t-1}$
adjustment rate	$\alpha_{j,k,h,t}$	depends on e, p, s
current relative price	$p_{j,h,t}$	$p_{jht} = p_{j-1,t,t-1} / \pi_t$
current fraction	$\omega_{j,k,h,t}$	$\omega_{jkh t} = (1 - \alpha_{jkh t}) \theta_{jkh t}$

Initial conditions and sticky prices. Let $p_{j-1,h,t-1}$ be the last period's relative price of a firm which last changed its price at date $t - 1 - (j - 1) = t - j$ when it was in microstate h . Let $\omega_{j-1,l,h,t-1}$ be the fraction of firms in this situation which charged this price and also had productivity level l . This information gives the joint distribution of productivity and prices at date t-1.

If such a firm chooses not to adjust, its relative price evolves according to

$$p_{jht} = p_{j-1,h,t-1} / \pi_t \quad (10)$$

where π is the current inflation rate (π_t is short-hand for $\pi(s_t)$ from above). That is, one effect on the date t distribution of relative prices will be the effects of inflation.

Endogenous fractions: There are two micro shocks which hit a firm in our model, so that its ultimate decisions are conditioned on its productivity (e) and its adjustment cost (ξ). For the purpose of accounting in our model, we find it convenient to specify that the productivity shock occurs first and then the adjustment cost shock.

As above, let $\omega_{j-1,l,h,t-1}$ be the fraction of firms which charged the price $p_{j-1,h,t-1}$ when they were in microstate l last period. As a result of stochastic productivity transitions, then, there will be a fraction

$$\theta_{jkh t} = \sum_l q_{lk} \omega_{j-1,l,h,t-1}$$

of firms that start period t with a j period old nominal price set in micro state h and have a microstate k in the current period.

However, not all of these firms will continue to charge the nominal price which they set in the past. To be concrete, consider firms with a j period old price which they set in microstate h and are now in k . Of these firms, let the adjustment rate be

$$\alpha_{jkht}$$

Then, the fraction of firms choosing to continue charging the nominal price set j periods ago will be

$$\omega_{jkht} = (1 - \alpha_{jkht})\theta_{jkht} \quad (11)$$

Taking all of these features into account, we can see that transitions are governed by two mechanisms: the exogenous stochastic transitions of the microstates (q_{lk}) and the endogenous adjustment decisions of firms (α_{jkht}). As discussed in prior sections, the adjustment decision depends on the firm's relative price, its microstate and the macroeconomic states in ways that introduce separate effects of j, k, h, t .

Given that firms currently in microstate k adjust from a variety of historical states, it follows that the fraction of adjusting firms is given by

$$\omega_{0kkt} = \sum_j \sum_h \alpha_{jkht} \theta_{jkht} \quad (12)$$

We use the redundant notation ω_{0kkt} to denote the fraction of adjusting firms in microstate k so that this is compatible with (??).

Since the distribution of microstates is assumed to be stationary, there is a constraint on the fractions,

$$\phi_k = \omega_{0kkt} + \sum_h \sum_j \omega_{jkht}$$

which is another way of describing the fraction of firms that are setting price and are in current microstate k .

3.6 State variables suggested by the accounting

There are two groups of natural endogenous state variables of the model suggested by the discussion above. One is the vector of past relative prices $p_{j-1,h,t-1}$ for $h = 1, 2, \dots, K$ and for $j = 1, 2, \dots, J_h$. The other is the fraction of firms that enter the period with a particular past microstate (l) and a relative price that was set j periods ago in microstate h .

$$\omega_{j-1,l,h,t-1} \quad (13)$$

Thus, the addition of microstates raises the dimension of the minimum state space elements introduced by the stochastic adjustment model structure from roughly $2*J$ to roughly $J*K + J*K^2$, where J is the maximum number of periods of nonadjustment and K is the number of microstates. However, this is only an approximation because the maximum number of periods can differ across microstates: J_{kh} is the endpoint suitable for firms currently in microstate k which last adjusted in historical microstate h .

3.7 The adjustment process

The dynamics of adjustment are highlighted by three figures.

Figure 6 shows the dynamics of adjustment for the DKW model. In each period, a fraction $\theta_{jt} = \omega_{j-1,t-1}$ of firms enters the period having a price which was set in $t - j$. Within the period, these firms adjust at rate α_{jt} and remain at rate $\eta_{jt} = (1 - \alpha_{jt})$.

Figure 7 shows the determination of the adjustment fraction, which depends on the gain from adjusting relative to the cost from adjusting. In this figure, there is a general adjustment cost function (the solid line) and the benchmark adjustment hazards from the model with Dixit-Stiglitz demand studied in Dotsey and King [2005], which was also displayed in Figure 2.

Figure 8 shows the modifications of the dynamics of adjustment introduced by microstates. For each price lag ($j-1$), microstate last period (l) and historical state (h), a fraction $\omega_{j-1,l,h,t-1}$ enters the period. Call the matrix of these initial conditions $\omega_{j-1,t-1}$. Then, the microstate transition process leads to a fraction of firms $\theta_{jkht} = \sum_l q_{lk} \omega_{j-1,l,h,t-1}$ having a price lag j , a current microstate k ; and a historical state (h). Of these, a fraction α_{jkht} of these firms chooses to adjust while a fraction $\eta_{jkht} = 1 - \alpha_{jkht}$ chooses not to adjust, leaving $\omega_{jkht} = \eta_{jkht} \theta_{jkht}$ charging relative price p_{jht} and experiencing microstate k . In Figure 8, these transitions are represented in matrix form. One thing which is important to stress, at this stage, is that we allow for zero adjustment or for complete adjustment in various situations (particular j,k,h entries).

Figure A: DKW99 Model
Evolution of fractions of price-setters carrying state variable p_{t-j}

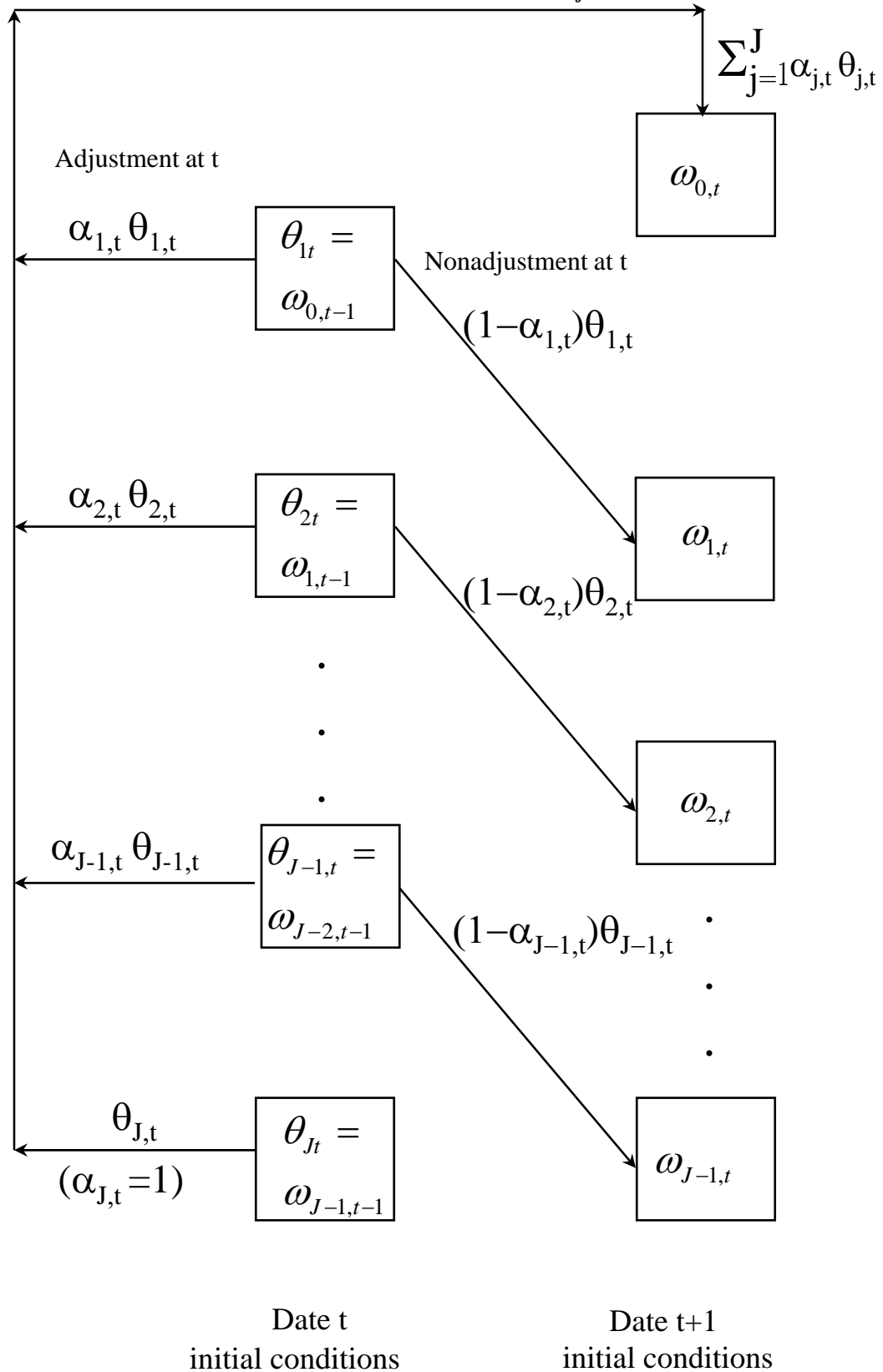

Figure B:

Costs and benefits determine the stochastic adjustment rate

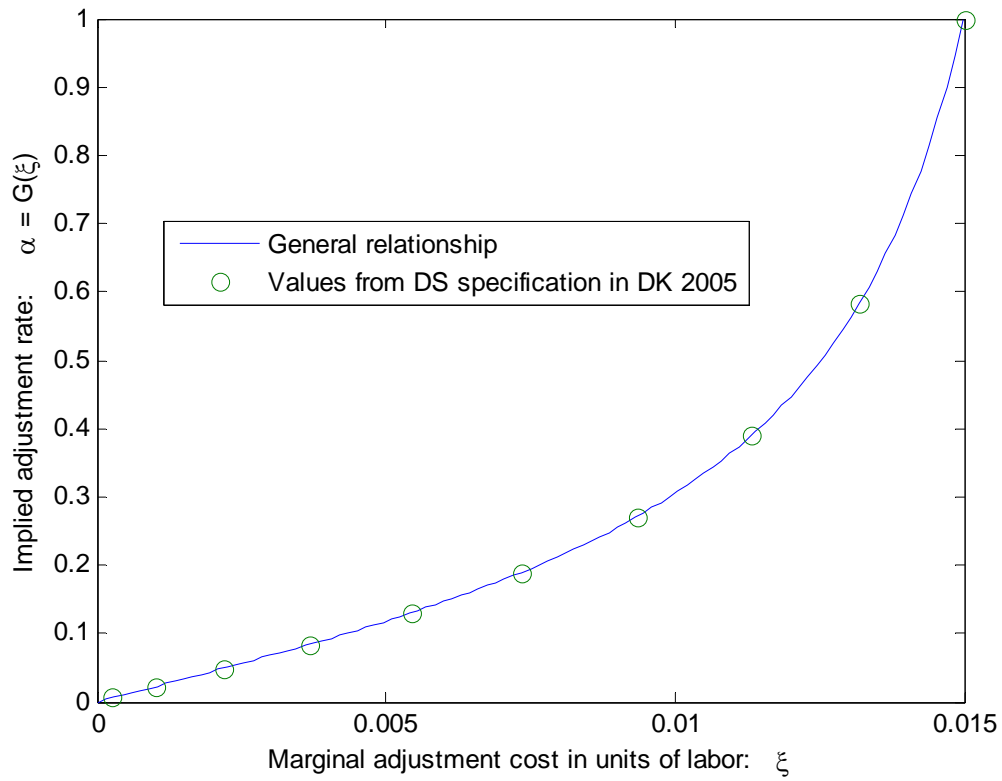
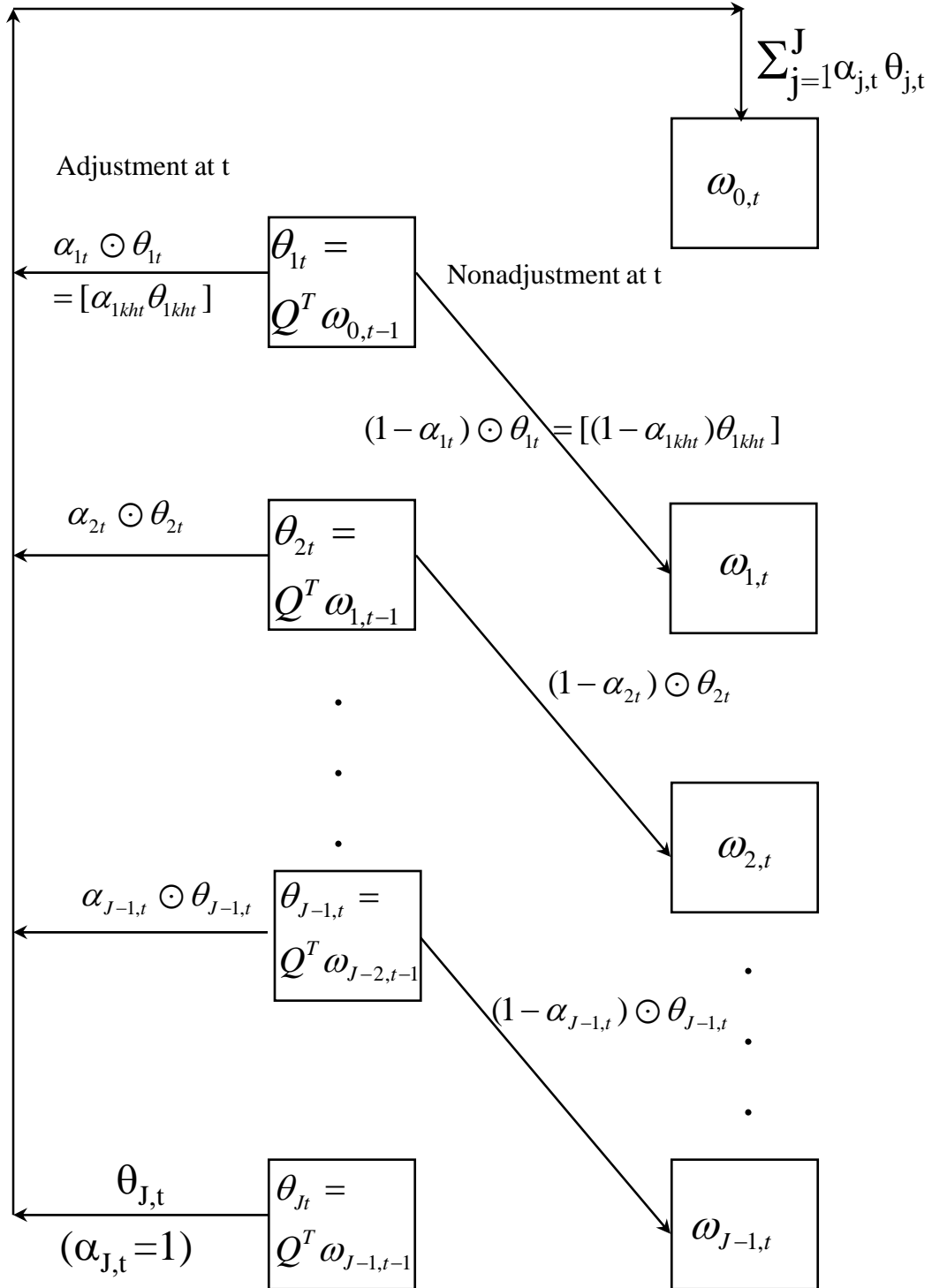

Figure C: Microstate Model
Evolution of fractions of price-setters:
Exogenous transitions (Q) and endogenous hazards (a)



Date t: micro shocks
and initial conditions

Date t+1
initial conditions

4 A particular DSGE model

We now imbed this generalized partial adjustment apparatus into a particular DSGE model, which is designed to be simple on all dimensions other than pricing so as to make clear the consequences of that mechanism. The starting point for our analysis is the analysis of Dotsey and King [2005], which shows that state-dependent pricing can be important for the dynamics of inflation and output. Throughout, we focus on a setting in which there is an economy-wide factor market for the sole input, labor.

4.1 The Household

As is conventional, there are two parts of the specification of household behavior, aggregates and individual goods.

4.1.1 Aggregates

We assume that there are many identical households that maximize

$$\begin{aligned} \max_{c_t, n_t} E_0 \left\{ \sum_t \beta^t \left[\frac{1}{1-\sigma} c_t^{1-\sigma} - \frac{\chi}{1+\phi} n_t^{1+\gamma} \right] \right\} \\ \text{subject to: } c_t \leq w_t n_t + \sum_j \sum_k \sum_k \omega_{jkh} z_{jkh} \end{aligned}$$

where c_t and n_t are consumption and labor effort respectively and z_{jkh} is the profits remitted to the household by a type (j, k, h) firm. The first order condition determining labor supply is

$$w_t = c_t^\sigma n_t^\gamma,$$

and, hence, ϕ^{-1} is the Frisch labor supply elasticity. The first order condition determining consumption is

$$c_t^{-\sigma} = \lambda_t \tag{14}$$

where λ_t is the multiplier on the household's budget constraint, which serves also to value the firms.

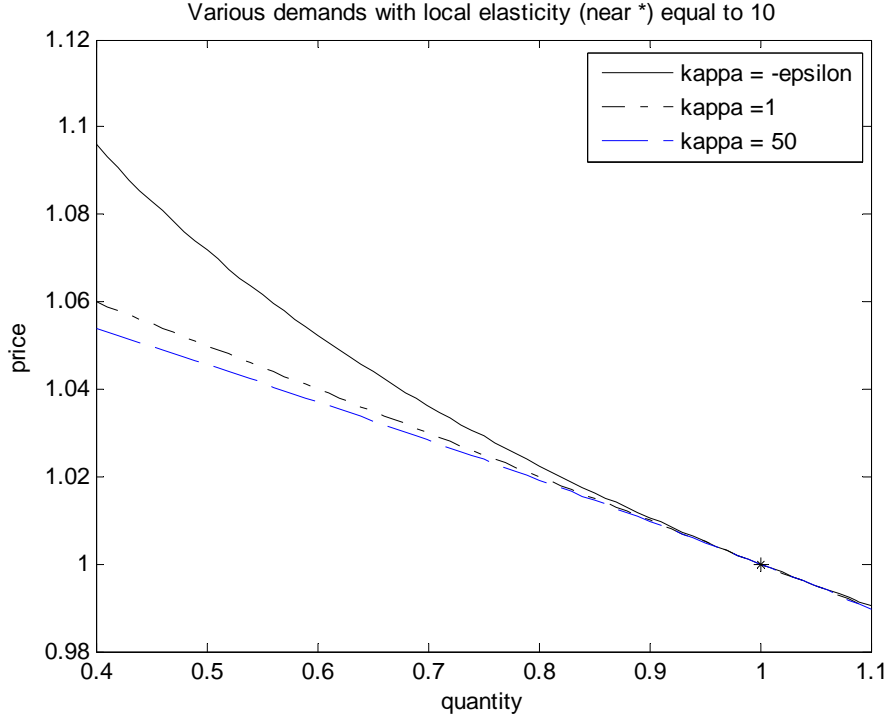

Figure 6:

4.1.2 The Demand Aggregator

We use an aggregator of the class suggested by Kimball [1995], $1 = \int_0^1 \varphi(x(i)) di$, where $x(i)$ is the relative demand for product i . The specific functional form of the aggregator is discussed further in the appendix. (This aggregator and the resulting demand are the same as that employed in DK [2005] but with a redefinition of parameters that is designed to make its structure and implications more transparent). It is designed to leads to relative demand curves which depend on the relative price $p(i)$ and a multiplier ς , taking the form

$$x\left(\frac{p(i)}{\varsigma}\right) = -\frac{\varepsilon}{\kappa} \left(\frac{p(i)}{\varsigma}\right)^\kappa + \left(1 + \frac{\varepsilon}{\kappa}\right) \quad (15)$$

In this expression, ε is the local demand elasticity at the point $x = 1, p = 1, \varsigma = 1$ and κ is a parameter that controls the shape of the demand curve. If $\kappa = -\varepsilon$, then the demand curve is of the constant elasticity form. If $\kappa = 1$, then the demand curve is linear. If $\kappa > 1$, then the demand curve displays a smooth-off kink, with the degree of convexity increasing in κ . These three possibilities are displayed in Figure 9.

4.2 Firms

There are two aspects of firm specification that warrant discussion. First, we adopt a simple production structure, but we think of it as standing in for some of the elements in the “flexible supply side” model of Dotsey and King [2006]. Second, we discuss the optimal pricing condition given the structure of demand, productivity and adjustment costs.

4.2.1 Factor demand and marginal cost

Production is linear in labor, $y(i) = a(i)n(i)$, where $y(i)$ is the output of an individual firm, $a(i)$ is the level of its technology, and $n(i)$ is hours worked at a particular firm.

Hence, real marginal cost, ψ_t , is given by $\psi_t = w_t/(a_t e_k)$ for a firm that is in microstate k at date t .

4.2.2 Optimal price-setting

The adjusting firm sets an optimal price which satisfies the FOC

$$0 = \lambda(s)z_p(p^*, e, s) + \beta E[\underline{v}_p(p', e', s')] \quad (16)$$

with $p' = p^*/\pi(s')$ and the nonadjustment probability being $\eta(p, e, s) = 1 - \alpha(p', e', s')$.

The marginal value for a nonadjusting firm is

$$\underline{v}_p(p, e, s) = \lambda(s)z_p(p, e, s) + \beta E[\eta(p', e', s')\frac{1}{\pi(s')}\underline{v}_p(p', e', s')] \quad (17)$$

with $p' = p/\pi(s')$.²

²Maximizing the “free adjustment value” (??) implies a first order condition,

$$0 = \lambda(\varsigma)z_p(p^*, v, \varsigma) + \beta E[\frac{1}{\pi(\varsigma')}v_p(\frac{p^*}{\pi(\varsigma')}, v', \varsigma', \xi')$$

The value function v takes the form

$$v(p, v, \varsigma, \xi) = \left\{ \begin{array}{ll} \underline{v}(p, v, \varsigma) & \text{if } \xi \geq \bar{\xi}(p, v, \varsigma) \\ [v^o(v, \varsigma) - \lambda(\varsigma)w(\varsigma)\xi] & \text{if } \xi \leq \bar{\xi}(p, v, \varsigma) \end{array} \right\}$$

so that

$$v_p(p, v, \varsigma, \xi) = \left\{ \begin{array}{ll} \underline{v}_p(p, v, \varsigma) & \text{if } \xi \geq \bar{\xi}(p, v, \varsigma) \\ 0 & \text{if } \xi \leq \bar{\xi}(p, v, \varsigma) \end{array} \right\}.$$

Since \underline{v}_p does not depend on ξ , we can express the FOC as in the text. A similar line of reasoning leads to the condition (??).

4.3 The monetary sector and macroeconomic equilibrium

To close the model, it is necessary to specify the monetary sector and to detail the conditions of macroeconomic equilibrium.

4.3.1 Demand for money

We further impose the money demand relationship $M_t/P_t = c_t$. Ultimately, the level of nominal aggregate demand is governed by this relationship along with the central bank's supply of money.

4.4 Supply of money

The model is closed by assuming that nominal money supply growth follows an autoregressive process,

$$\Delta \log(M_t) = \rho \Delta \log(M_{t-1}) + x_{mt},$$

where x_{mt} is a mean zero random variable.

4.5 Macroeconomic equilibrium

There are three conditions of macroeconomic equilibrium. First, labor supply is equal to labor demand, which is a linear aggregate across all the production input requirements of firms, $\sum_j \sum_k \sum_k \omega_{jkh} n_{jkh}$, and also includes labor for price adjustment. Second, consumption must equal output. Third, money demand must equal money supply.

4.6 Parameters

The microstate process is shown in Table 2: there are three possible values of e , which involve symmetric increases and decreases in productivity. Irrespective of the values of the parameter δ , the specification implies that there is a stationary distribution with a peak at mean productivity (unity). The extent of dispersion is governed by δ : the current value is set at .05 (5%) and the associated standard deviation of productivity is .0378 (3.78%). The first-order autocorrelation is .75 in Table 2. Since productivity is fairly persistent, there is a smaller standard deviation of productivity changes: .0267 (2.67 %). But, conditional on a change, the average productivity change is .0571 (5.71%).

Table 2: Micro state driving process

Markov transitions	$Q = \begin{bmatrix} .8 & .15 & .05 \\ .10 & .8 & .10 \\ .05 & .15 & .8 \end{bmatrix}$
Support	$\underline{e} = \begin{bmatrix} 1 - \delta & 1 & 1 + \delta \end{bmatrix}$
Stationary distribution	$\Phi = \begin{bmatrix} .286 & .428 & .286 \end{bmatrix}$
Productivity: ($\delta = .05$)	std =.0378, autocorrelation=.75
Productivity change	std = .0267, mean abs prop change=.0571

As listed in Table 3, the other parameters employed are those from DK 2005 for comparability with the results of that analysis without microstates. Our assumption is that $\mathcal{B}=.015$, which means that the largest adjustment cost is $.015/.20$ or 7.5% of work time. However, most adjustments involve much smaller adjustment costs.

5 The stochastic steady state

In our micro-state model, the relevant stochastic steady state is the stationary distribution that prevails when there are no macroeconomic shocks, so that s_t is constant. In this steady state, individual firms are subject to persistent productivity shocks (e) and temporary adjustment cost shocks (ξ), so that there are important fluctuations in their circumstances.

5.1 Computation

We compute this stochastic steady state using the following algorithm, which contains two parts. First, we solve for various “microvariables” of interest given aggregates. Specifically, we begin with values of firms $v = [v_0 \ v_1 \ v_2 \ \dots v_{J-1}]$ and a set of macroeconomic variables m discussed further below. We then calculate in turn: (i) an optimal adjustment policy from

the cost-benefit condition (??); (ii) an optimal pricing policy from the Euler equation (??); and (iii) a new set of values from the Bellman equation (??). These various calculations take place for each point in the stationary distribution: like the calculation of the steady state in simpler models (e.g., the growth model), it is not necessary to determine the full policy function but only its stationary point.

Taking all of the calculations into account, we can represent these three steps as follows.

$$\alpha = \alpha(v, m) \tag{18}$$

$$0 = f(p, m) \tag{19}$$

$$v = v(\alpha, p, m) \tag{20}$$

This process can be iterated until there are equilibrium values of α, p, m given the macro variables. Second, we have macroeconomic equilibrium conditions which specify that the commodity market clears; that the labor market clears; that the aggregate good is produced efficiently from its elements; and that individual prices are consistent with the price level. These conditions implicitly determine a vector of macroeconomic variables, m , given the distribution of prices etc. Write the macroeconomic “excess demands” as a vector-valued function A and thus write the macroeconomic equilibrium conditions as

$$0 = A(m, p(m), \omega(\alpha(m)), \alpha(m)) \tag{21}$$

where $p(m)$ and $\alpha(m)$ indicates that the process of iterating on (??)-(??) yields solutions for p and α given the macrovariables. The fractions ω enter into the macroeconomic equilibrium conditions because these are weights in various aggregations, such as output and labor. However, given adjustment rates α and the microstate transition process, we can directly compute

$$\omega(\alpha). \tag{22}$$

Hence, there is a well-defined scheme for computing the stationary distribution, which is to adjust the m values until the condition (??) is satisfied. Several comments about this computational process are in order: (i) although it involves the determination of many variables, it is reasonably fast, taking less than a minute on a personal computer at present, even though the programs have not yet been optimized for speed; (ii) because the “micro” portion of the algorithm corresponds to stationary points of a dynamic program, its convergence is guaranteed and computational tricks from dynamic programming can be exploited; and (iii) because the “macro” portion of the algorithm involves only a few variables and very

well-behaved “supply and demand” schedules, it can be solved without use of complicated zero-finding methods.³ By contrast, in prior work such as DKW [1999] and Dotsey and King [2005, 2006], we computed the stationary distribution by simultaneously solving for macro and micro variables. That approach was less numerically stable.

5.2 Learning about the stationary distribution

We are interested in learning about the nature of price adjustment in the stationary distribution for three reasons. First, we are interested in learning about the effects of price stickiness on consumption, labor, and output in a setting in which prices actually play an allocative role and therefore in which price-stickiness has potential real consequences even in steady state. Second, the stationary distribution should be a guide to the average pattern of micro price adjustment, so that it can be compared to the results of existing empirical studies of micro-price adjustment and also serve to guide future empirical studies. Third, the pattern of price adjustment is important for aggregate dynamics in response to shocks, both in terms of the pattern of average “lag weights” in the pricing block and in terms of understanding the incentives that firms have to alter the timing of price adjustment in response to shocks.

In this draft, our focus is on the DS economy for two reasons: (i) it is the specification most widely employed by macroeconomists; and (ii) it is the specification in which the effects of microstates is most dramatic.

Information on micro productivity shifts

Figure 10 displays the stationary distribution of productivity and productivity changes. Panel A shows that, at any point in time, there are 42.9% of the firms with the “normal” level of productivity ($e=1$) and 28.6% of the firms have high productivity ($e=1.05$) or low productivity ($e=.95$). Panel B shows that 80% of the firms experience no productivity change at each date. There are also firms with large productivity increases: 8.6% are faced with a change of .05 and 1.4% are faced with a change of .10. Finally, there are similar fractions of firms with large productivity declines: 8.6% are faced with a change of -.05 and 1.4% are faced with a change of -.10.

Our assumption is that inflation takes place at 1% per period, which we specify to be a quarter of a year. If prices were completely flexible and there were DS demand, then this figure would translate directly into information on relative prices. The first panel would

³Both the “micro” and “macro” parts of the algorithm use a simple Gauss-Newton approach. In the micro part, this is to solve the price Euler equation.

capture the distribution of relative prices. The second would describe relative price changes. To get the distribution of nominal price changes, we would simply need to add .01 to each value on the horizontal axis: 80% of the firms would have a price change at the inflation rate, so as to keep their relative price constant.

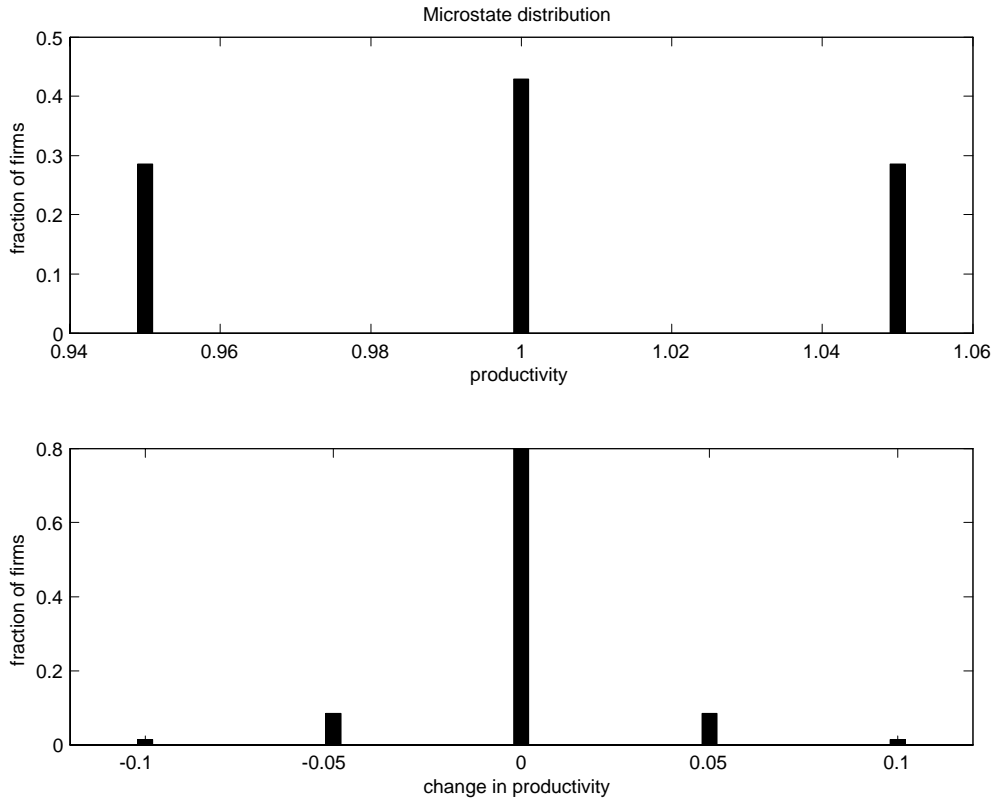

Figure 10

As we shall see, there are important effects of costly price adjustment on both the distribution of prices and price changes.

SS result #1: micro productivity shocks increase average stickiness

Within the DS setting, introduction of micro productivity shocks increases the average stickiness in the economy, as shown in Figure 11. In this figure, two distributions are displayed. The first is the distribution of firms by “time since last adjustment” reported in DK-2005: this is the ‘o’ distribution for which there is a mean age of nominal price of 3.27 and the oldest price is 9 quarters in age. When micro productivity states are added to the same economy, then some firms will tolerate more lengthy stickiness, so that the mean age increase to 3.90 and the oldest price is 17 quarters. To be clear, each of the points on the microstate distribution is the sum across firms with heterogenous productivity levels and there is great variety in the pattern of adjustment conditional on microproductivity that we

will discuss further below. In terms of the accounting framework discussed in a prior section, the constructs in Figure 11 are calculated as follows. The fraction of firms with a price of age j is

$$\bar{\omega}_j = \sum_k \sum_h \omega_{khj}$$

and the mean age of price is calculated as $\sum_{j=0} [j * \bar{\omega}_j]$.

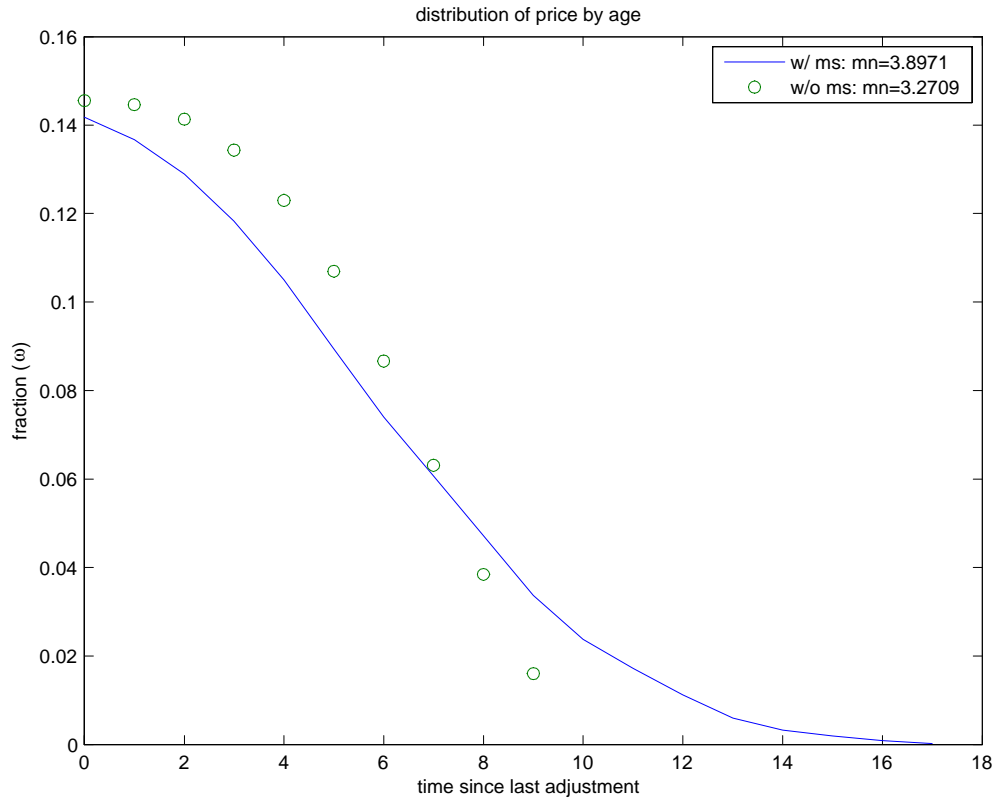

Figure 11

SS result #2: a conditional relationship between prices and adjustment

In empirical studies of the nature and consequences of adjustment dynamics, it standard to graph adjustment hazards versus a state variable, such as the relative price in our model. Figure 12 shows the nature of this relationship for the three productivity levels in our economy.

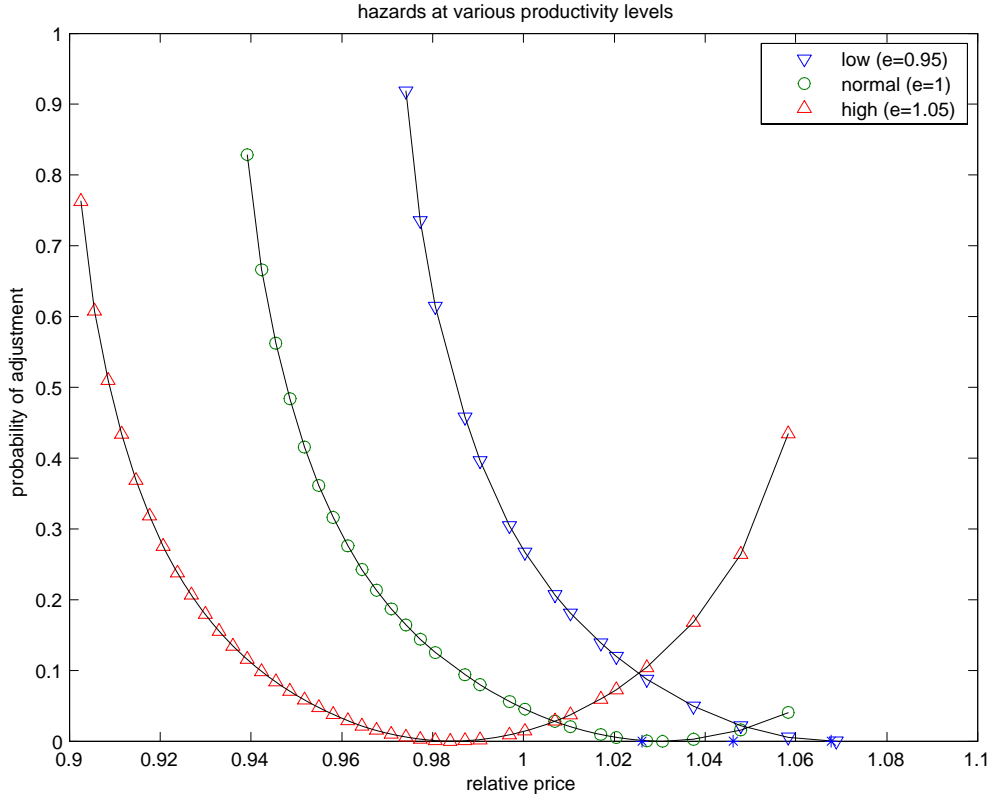

Figure 12

The relationship for high productivity ($e=1.05$) could have been borrowed from Caballero and Engel [1993]. It shows that the hazard is lowest – essentially zero – at a relative price of .98 and increasing for higher or lower relative prices. The bottom of the “bowl” occurs at the relative price of .98, even though a high productivity firm would choose a relative price of about .95 (that is, $1/1.05$) with flexible prices.⁴ This higher price obtains because a firm that is adjusting with relative productivity $e = 1.05$ recognizes that it may hold its nominal price fixed for some time, a phenomenon which has been termed the “frontloading” of price changes. With our assumptions about the shape of the profit function (via our assumptions about demand elasticity), a 10% increase or decrease in the relative price is sufficient to induce full adjustment. The symbol ‘ \triangle ’ in the figure highlights a point where the relationship is actually evaluated in our steady-state calculations, but this point is not necessarily one in which there is a positive fraction of firms in the stationary distribution.

⁴This assumes that the pricing rule under flexible prices is

$$p = \mu \frac{w}{ae}$$

where μ is the markup and w is the real wage as will be true for the DS demand specification. It also assumes that $\mu w/a$ is 1, as will be approximately the case in a flexible price model. That is, in general equilibrium, the wage will move directly with aggregate productivity and inversely with the markup.

However, there is positive mass on relative prices in the range between .92 and 1.06 in the stationary distribution, as may be seen by looking at detailed information in Appendix B.

Figure 12 also shows the relationship between relative price and hazard for firms with “normal” productivity of $e = 1$ and “low” productivity of $e = .95$. For the lowest productivity level, a firm sets a relative price of $p^* = 1.069$, recognizing that this will be eroded by ongoing inflation while it is maintaining its nominal price fixed. The one-sided nature of the adjustment process is characteristic of models without micro-states such as the reference model of DK 2005. A drop in relative price of 10% is again sufficient to induce full adjustment.

Comparison of the high and low productivity firms actions and adjustment probabilities helps us understand the increase in stickiness displayed in Figure 11.

Some firms will start with high productivity and make a transition to low productivity. But these firms will adjust quickly. More precisely, a high productivity firm would start with a relative price of $p^* = .98$. If it made an immediate change to the low productivity state (i.e., a change after just one period of high productivity), then it would adjust with probability one.

Some firms will start with low productivity and make a transition to high productivity. It is useful to consider a firm that sets a relative price of $p^* = 1.069$ and then makes a change to high productivity after one period. Inflation will have eroded its relative price to $p = 1.058$. At this relative price, there is an adjustment probability of only about .3. Further, if it stays in the high productivity state, then this firm will have a relatively low probability of adjusting (no greater than 20% in each period and sometimes close to zero) for the next three years. That is, given a one percent inflation rate, its relative price will be $p^*\pi^{-12} = .949$ after 12 quarters and there is only a 10% chance of adjustment along the $e = 1.05$ “bowl” with this relative price.

Hence, the elongation of the price distribution, as displayed in Figure 11, arises from the endogenous selection of high productivity firms within the stationary distribution of relative prices.

SS Result #3: Average hazards differ from normal hazards

Under DS demand, a model without micro-states gives a good guide to the nature of the hazard for a firm that starts in and stays in the “normal” productivity state of $e = 1$, as displayed in Figure 13. In particular, both hazard functions start out quite low, since there is a relatively flat profit function with DS demand (see, for example, the discussion in DK2005). Further, adjustment is completed in each case after 10 quarters.

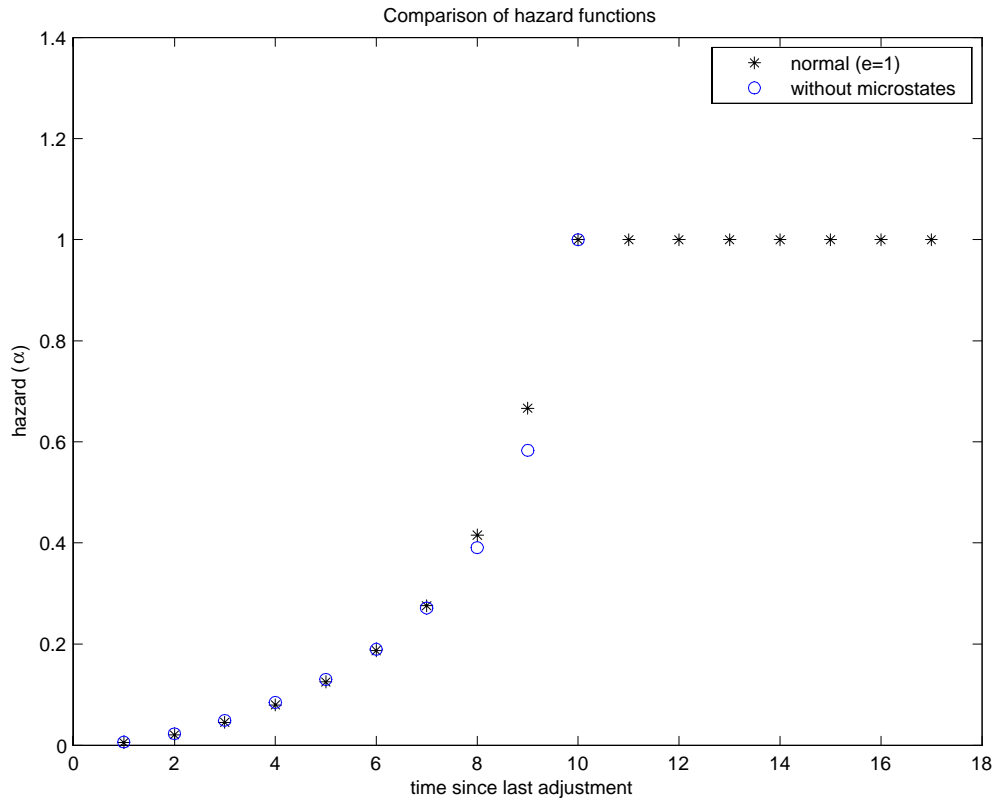

Figure 13

By contrast, the behavior of the average hazard – the construct that is most directly linked to the sorts of summary statistics compiled in the ECB’s inflation persistence project – is quite different. The average hazard is calculated as

$$\bar{\alpha}_j = \frac{\bar{\omega}_{j-1} - \bar{\omega}_j}{\bar{\omega}_{j-1}}$$

i.e., as the fraction of firms that have adjusted after j periods, given that they have held their price fixed for $j - 1$ periods. Note that it is a proportionate slope of the distribution in Figure 11.

Relative to the normal hazard, the average hazard displayed in Figure 14 is initially marginally higher and then substantially lower. In our discussion of Figures 11 and 12, we have seen the reason: the firms that are willing to tolerate incomplete adjustment are high productivity firms, even those that have relative prices which are high because they were once low productivity firms.

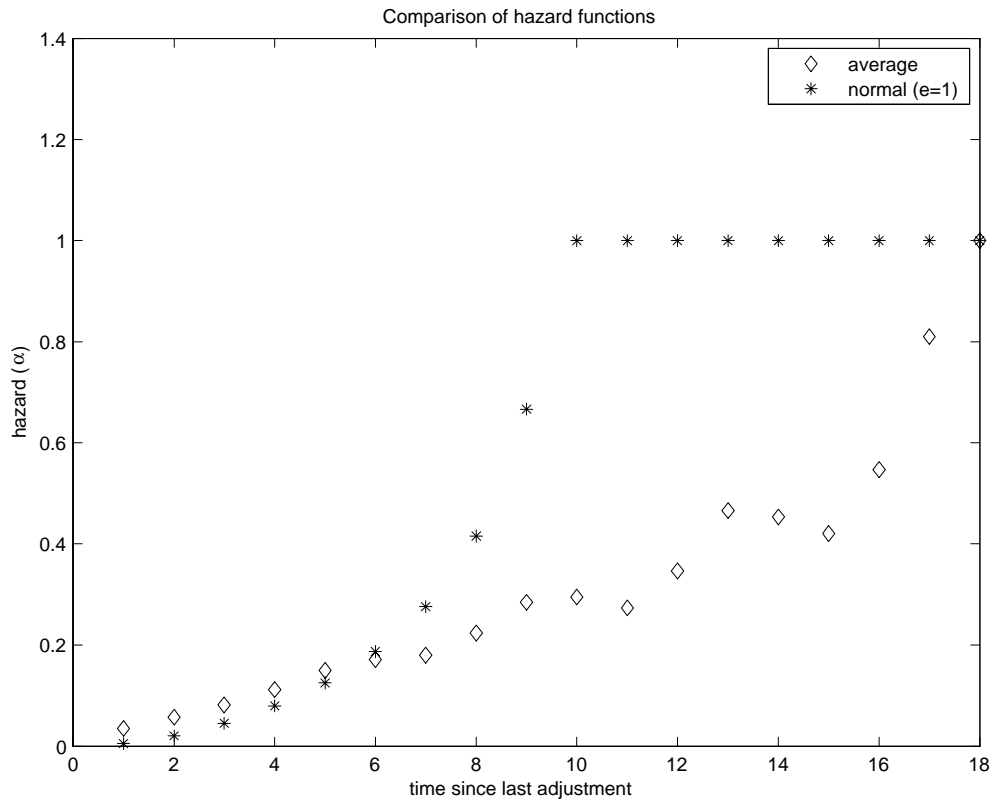

Figure 14

SS Result #4: The distribution of relative prices

The distribution of relative prices is displayed in Figure 15. In comparison with the productivity distribution that is displayed in Figure 10, which had 42.9% of the firms at $e=1$ and the remainder equally split between $e=1.05$ and $e=.95$, there is now a distribution that is wider ranging and smoother. Because there is positive average inflation, firms set their nominal prices understanding two features of the sticky price model. First, there will be an erosion of relative prices by inflation. Second, there are future adjustment outcomes that will mitigate the effects of inflation.

More specifically, the distribution reflects the fact that high productivity firms are more willing to tolerate a relative price that departs from target than are other firms. If the relative price is high (relative to the target⁵ of $p^* = .98$), a high productivity firm probably does not adjust, in part because it knows that the relative price will fall through time as a result of inflation.

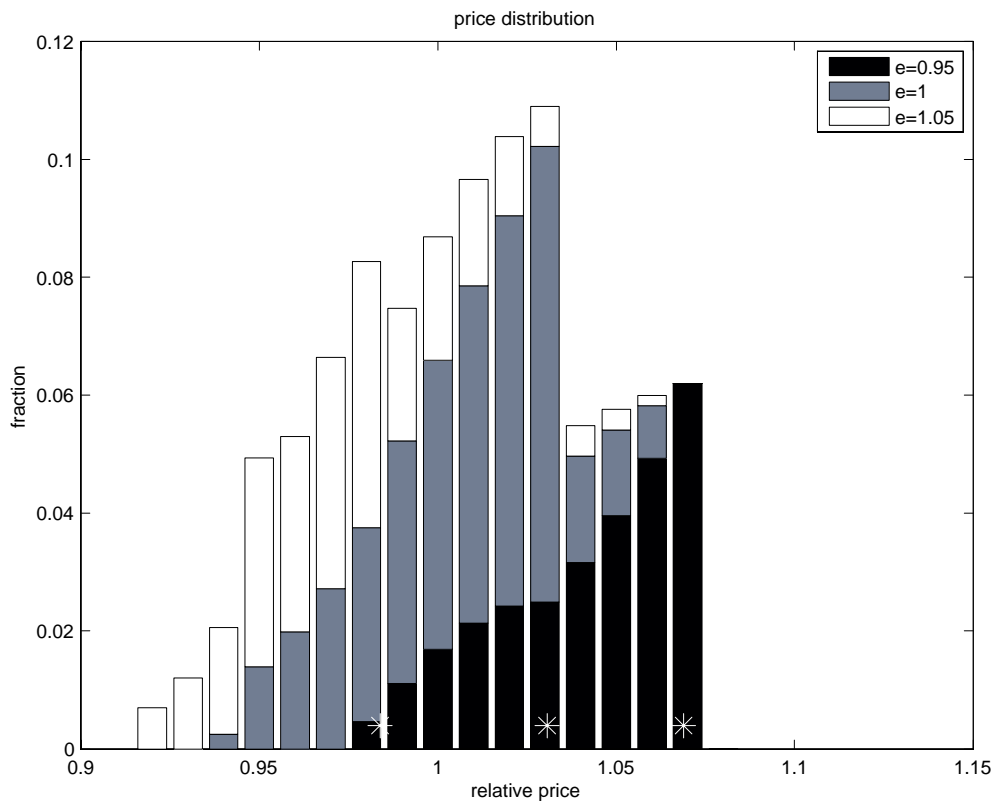

Figure 15

⁵Targets are included Figure 15 by placing a white "*" near the bottom of the relevant "bin" in the histogram.

SS Result #5: the distribution of price changes

The distribution of price changes shown in Figure 16 differs from the distribution of productivity changes shown in Figure 10 on several dimensions. First, even though 20% of firms experience productivity changes in a period and even though these changes are large, only 14% of firms change their nominal price in each period. Second, the mean absolute productivity change is large (5.71%) but the mean absolute price change is even larger (7.4%). Third, even though there are many large negative productivity changes (10% of all changes and 50% of all non-zero changes), there are few negative price changes in the stationary distribution. Again, those firms which experience productivity increases typically choose to wait to change their prices.

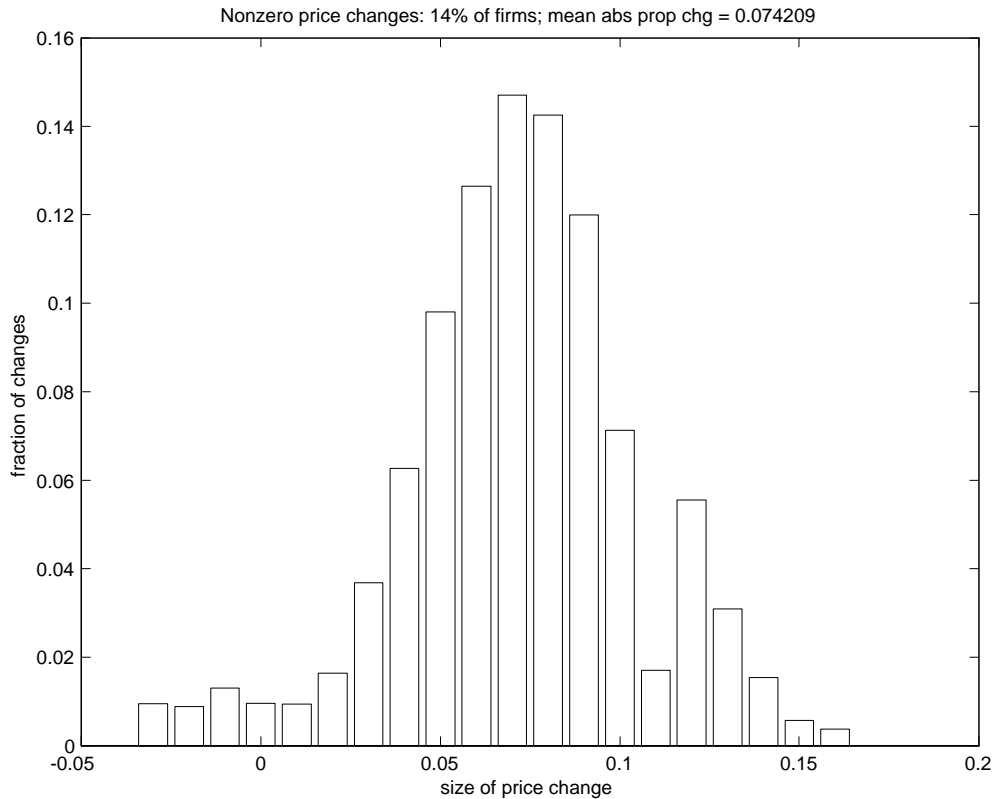

Figure 16

Steady state of the K demand model

While there are quite interesting effects of adding microstates to the DS demand model, as just discussed, there are much less dramatic implications for the K-demand model, for good economic reasons. In the K-demand model, firms do not wish to have a high relative price, since substantial declines in revenue occur by doing so. Accordingly, in the steady state, micro productivity shifts have relatively small effects (i) on the timing of adjustment and (ii) on the distributions of relative prices and price changes. A detailed graphical report on these implications is provided in Appendix C, in a form that mirrors the text presentation and Appendix B information on the DS-demand model.

6 Consequences for aggregate dynamics

We are interested in the consequences of introducing micro-states for the aggregate dynamics of inflation and real activity. Our focal point is the DS-demand economy whose dynamics were explored in Figure 4 above, drawn from DK-2005, for the case in which there are no micro-states. In our discussion of those dynamics above, we noted that they looked very different from the implications of most sticky price models and from estimates of the effects of monetary shocks. However, when the micro-state structure detailed in Table 3 is introduced, there are dramatically different dynamic responses, as shown in Figure 17. We turn now to the analysis of this model, working to understand aspects of the responses in both Figures 4 and 17.

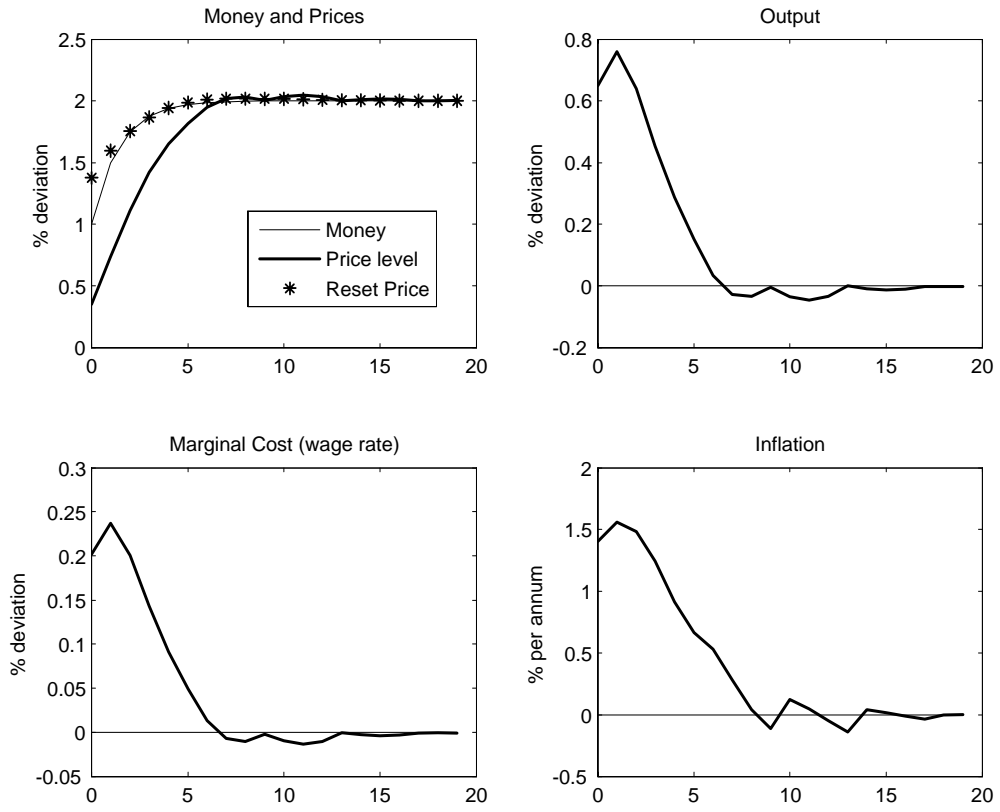

Figure 17

6.1 The central mechanism without microstates

In the simple state-dependent pricing model with DS demand, as captured in Figure 4, there is a very substantial effect of the money stock on the price level at the impact date ($t=0$): the price level rises by about .75 of the increase in the money stock. This is a result of two features. First, there is a large increase in the “reset price”, the price to which the subset of adjusting firms change (evident in Figure 4). Second, there is a large increase in the fraction of firms which choose to adjust (not shown in Figure 4, but on the order of an increase from the 15% of firms shown in Figure 11 to over 50% of all firms).

That is: in the SDP model shown in Figure 4, there is an extremely strong positive interaction across firms in terms of the timing of their adjustments: if more firms adjust their prices, then this increases the price level by a greater degree, which makes it efficient for more firms to adjust. It is this strong positive interaction that leads the DS demand model without microstates to display unorthodox dynamics in its most basic form.

6.2 Inflation and adjustment with microstates

When micro productivity fluctuations are added, there are three factors influencing the timing of adjustment by firms. The first two are present in all SDP models built along generalized partial adjustment lines. First, firms will adjust when they get a particularly low adjustment cost draw. Second, firms will adjust more frequently when their benefits to adjustment are relatively high due to aggregate factors, such as the evolution of the price level discussed above. The third is specific to models with microstates: firms will adjust when they make transitions between various levels of productivity.

The interaction between the aggregate adjustment fraction and the inflation rate in the DS-demand model is shown in Figure 18. With a rise in the inflation rate, there is a substantial rise in the adjustment rate in the microstates model: the adjustment rate (“*”) rises by between 3% on impact as the inflation rate rises by 1.5% when measured at an annual rate. In terms of the price level (shown in Figure 17) there is an adjustment rate increase of 3% when the price level rises by about .4%.

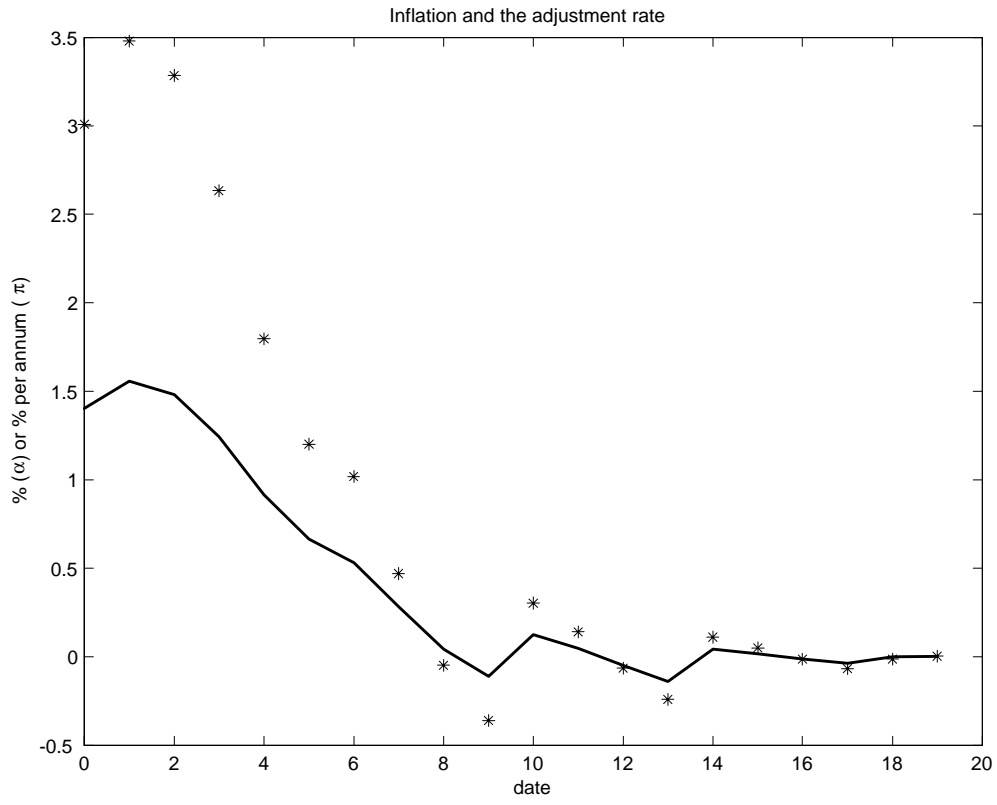

Figure 18

There are four observations to be made about this pattern of results, which bear on results elsewhere in the literature.

First, relative to the DK2005 model without microstates, there is weaker positive interaction between the price level and the inflation rate. This is an intuitive finding: when the adjustment decision is based in part on the micro productivity situations of firms, they will be less responsive to aggregate developments. Hence, we have a dynamic finding which echoes the steady state finding (result #1) that there is increased stickiness when microstates are introduced.

Second, Golosov and Lucas [2003] argue that menu cost models with large micro productivity shocks generate only small nonneutralities. The Figure 18 findings are in that spirit, even though there is much less frequent price adjustment in the Figure 11 distribution than is posited by Golosov and Lucas. However, it is important not to misinterpret our result (or GL's). Adding microstates to the DK2005 model generates a relatively small non-neutrality in the current setting, but it also brings the pattern of dynamics closer to impulse response patterns estimated for actual economies.

Third, Klenow and Kryvtsov [2004] argue that SDP models should be designed to capture decompositions of the inflation rate into components attributable to size and frequency of price adjustments. We think that our quantitative framework can be employed to determine how to best design such decompositions: like other SDP models, it suggests that the decomposition is a subtle one because any SDP model mandates that many price adjustments are large, at least in the sense of involving large deviations from firm-level targets. For this reason, small variations in adjustment rates may play a larger role than suggested by the KK decomposition. However, these reservations about a decomposition do not apply to the direct measurements by KK of the fraction of price adjustments taking place within a particular survey period of the CPI or to the similar measurements made by the various teams in the EuroSystem's inflation persistence project. From the perspective of these studies, there is excessive volatility in the fraction of firms adjusting prices displayed in Figure 18: the addition of microstates to this DK-2005 example has only reduced the extent of adjustment response to aggregate conditions from "extreme" to "large". However, KK [2004] experiment with modifications of the adjustment cost structure in an attempt to bring SDP dynamics in line with aggregate evidence on the volatility of the frequency of price adjustment. While they need extreme versions of cost distribution parameters to meet their objectives within a model without microstates, the current analysis suggests that more modest variations would be necessary within models that have microstates.

Fourth, Gertler and Leahy [2005] suggest that SDP models with micro productivity shocks will resemble a time dependent model without micro productivity shocks, specifically

constructing an example in which an SDP framework gives rise to a Calvo-style inflation equation but with an altered interpretation of the “slope” coefficient that links inflation to marginal cost within that model. This perspective is one that we can study in our quantitative framework. For example, we can make a comparison between the output and inflation dynamics that obtain in the DS model if there is an identical steady-state pattern of adjustment and if the near-steady-state dynamic adjustment of the α 's is active (SDP) or shut down (TDP) as in Figures 19 and 20.

While the SDP model does appear to be a “more neutral” version of its TDP counterpart, the relationship does not seem to be one that will be well captured by a simple transformation of the slope parameter in the standard Calvo approach to pricing. For example, Mankiw [200x] has argued that all sticky price models are empirically deficient because they deliver peaks in inflation responses to monetary disturbances that arise no later than the peak in output response. The TDP dynamics displayed in Figures 19 and 20 involve an inflation delay, so they could not easily be captured by a Calvo specification. While the inflation and output responses are coincident in the SDP case with DS-demand, other SDP specifications lead to inflation peaks after output peaks (see DK 2005). For this reason, it seems unlikely that there is a general mapping between SDP models and Calvo models.

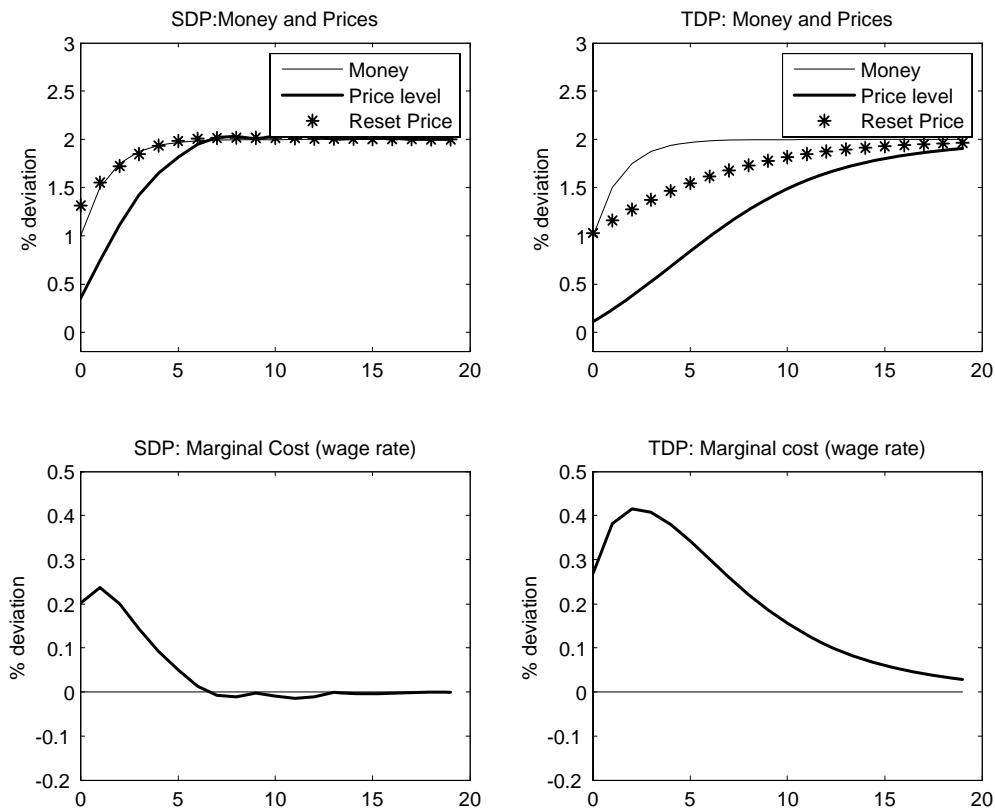

Figure 19

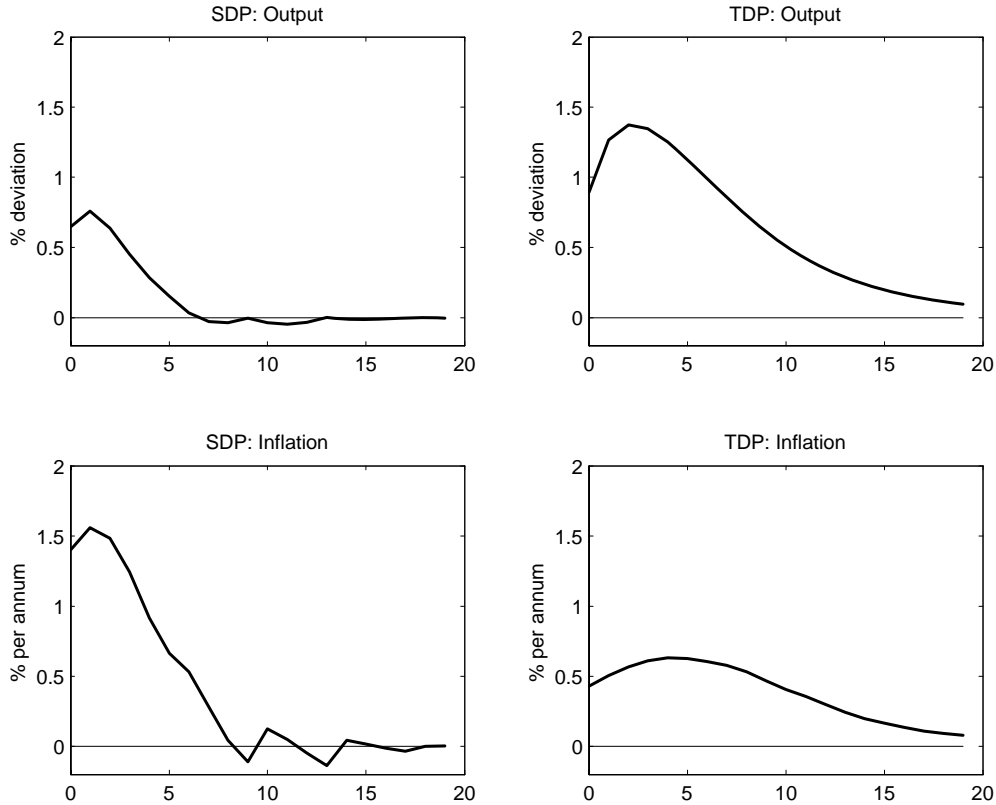

Figure 20

7 Conclusions

Generalized partial adjustment models in the pricing and other areas can be extended to study the influence of firm-level or plant-level shocks to productivity and demand.⁶ In this draft, we have started to investigate how the introduction of micro-productivity states affects:

(i) micro observations such as price adjustment hazards; the distribution of relative prices; and the distribution of nominal price changes;

(ii) the aggregate dynamics of inflation and output, including information on the fraction of firms opting to adjust prices at each point in time;

To undertake this investigation, we developed a framework that blends discrete states at the micro level, governed by a Markov chain, and continuous dynamics at the macro level, which can be approximated using linear systems methods.

⁶See King and Thomas [forthcoming, 2006] for a discussion in the context of labor demand.

References

- [1] Ball, L., Romer, D., 1990. Real rigidities and the non-neutrality of money. *Review of Economic Studies* 57 (2), 183-203.
- [2] Ball, L., Romer, D., 1991. Sticky prices as coordination failure. *American Economic Review* 81 (3), 539-52.
- [3] Bilal, M. and P. Klenow, "Some Evidence on the Importance of Sticky Prices", *Journal of Political Economy* 112, October 2004, 947-985.
- [4] Caballero, R., Engel, E., "Microeconomic rigidities and aggregate price dynamics", *European Economic Review* 37 (1993, no.4), 697-717.
- [5] Caballero, R., Engel, E., 1999. "Explaining investment dynamics in U.S. manufacturing: a generalized (S, s) approach," *Econometrica* 67 (1999, no. 4), 783-826.
- [6] Calvo G. 1983. "Staggered Prices in a Utility Maximizing Framework" *Journal of Monetary Economics*, 383-398.
- [7] Caplin, A., Spulber, D., 1987, "Menu costs and the neutrality of money", *Quarterly Journal of Economics* 102 (4), 703-726.
- [8] Caplin, A., Leahy, J., 1991. "State-dependent pricing and the dynamics of money and output", *Quarterly Journal of Economics* 106 (3), 683-708.
- [9] Dixit, A.K., and Joseph E. Stiglitz (1976). "Monopolistic Competition and Optimum Product Diversity", *American Economic Review*, **67**, 297-308.
- [10] Dotsey, M., King, R.G., Wolman, A. L., 1999. State-dependent pricing and the general equilibrium dynamics of money and output. *Quarterly Journal of Economics* 114 (3), 655-90.
- [11] Dotsey, M., and R.G. King, "Implications of State-Dependent Pricing for Dynamic Macroeconomic Models," *Journal of Monetary Economics*, January 2005.
- [12] Dotsey, M., and R.G. King, "Production, Pricing, and Persistence," forthcoming *Journal of European Economic Association*, September 2006.
- [13] European Central Bank
- [14] Golosov, M. and R.E. Lucas, 2003. Menu costs and Phillips curves. NBER Working Paper #10187.

- [15] Kemeny, J. G. and Snell, J. L. *Finite Markov Chains*. New York: Springer-Verlag, 1976.
- [16] Kimball, M., S., 1995. The quantitative analytics of the basic neomonetarist model. *Journal of Money, Credit, and Banking* 27 (4 part2), 1241–77.
- [17] King, R.G. and J.K. Thomas. “Partial Adjustment without Apology”, forthcoming *International Economic Review*, September 2006.
- [18] Klenow, P., and O. Kryvtsov, “State-Dependent or Time-Dependent Pricing: Does It Matter for Recent U.S. Inflation?” June 2004, <http://www.klenow.com>.
- [19] Mankiw, N. G., 2001. “The inexorable and mysterious trade-off between inflation and unemployment”. *The Economic Journal* 111 , C45-C61.
- [20] Midrigan, Virgiliu, 2006. “Menu Costs, Multi-Product Firms, and Aggregate Fluctuations.” Manuscript.
- [21] Willis, J., 2001. Magazine prices revisited. working paper 01-15 Federal Reserve Bank of Kansas City.
- [22] Woodford, M., 2003. *Interest and Prices: Foundations of a Theory of Monetary Policy*. (Princeton University Press, Princeton).
- [23] Yun, T., 1996. Nominal price rigidity, money supply endogeneity, and business cycles. *Journal of Monetary Economics* 37 (2), 345–70.